

**WARNING**

- Before use, check the wheels to make sure that there are no bent or loose spokes, dents, scratches or cracks on the rim surface. Do not use the wheel if any of these problems are found.
- The wheel is designed for cross-country riding. Do not use it for downhill riding, otherwise the wheel may become bent or otherwise damaged, and accidents may occur as a result.
- If the quick release mechanism is not used correctly, the wheel may come off the bicycle and serious injury could result. Read the Service Instructions for the quick release mechanism thoroughly before use.
- The WH-M959 is designed exclusively for use with disc brakes. Do not use these wheels with rim brakes.
- When installing the rotor to WH-M959-disc and WH-M575-disc front wheels, be sure to use the mounting bolts (L=9 mm) and locking plate which are provided. If other types of bolt are used, there is the danger that the rotor may not be secured tightly enough. When installing the rotor to the rear wheel, use the mounting bolts and locking plate which are provided with the rotor.
- Use rim tape which is wide enough to cover the spoke holes completely, otherwise sudden punctures may occur, and accidents may occur as a result.
- Be sure to carefully read the Service Instructions for the disc brakes also.
- Obtain, read and carefully service instructions when installing parts. A loose, worn, or damaged parts may cause injury to the rider. We strongly recommend that only genuine Shimano replacement parts be used.

**CAUTION**

- Use of genuine Shimano spokes, nipples and washers is strongly recommended. If non-Shimano parts are used, the area where the nipple seats into the hub flange may become damaged.
- Before use, check that there are no pieces of metal or other foreign objects sticking to the brake pads. If any such items are present, they may cause damage to the hub when the brakes are applied.
- The nipples have large diameters and are easy to rotate in order to make it easier to increase the spoke tension. However, be careful not to overtighten the nipples when adjusting the spoke tensions. If the nipples are overtightened, damage to the rim may result. (We recommended that you ask authorized bicycle dealers to make the adjustments.)

**Specifications**

Model number	WH-M959-disc	WH-M575-disc	WH-M535
Speeds	9		
No. of spokes	16		
Applicable spoke length	For front	260mm	262mm
	For rear	260mm	260mm
Rim width	24mm		
Rim size	26"		
Applicable tire size	26 × 1.5 ~ 2.25		
Applicable brakes	Disc brake	Disc brake V-Brake	V-Brake

**Note:**

- Use tire tubes with valve lengths of 50 mm or more.
- Special spoke wrenches are available as optional accessories.
- We recommend that you ask authorized bicycle dealers to adjust the spoke tensions if there is any initial play in the spokes and after the first 1,000 km of riding.
- A reflector (SM-RF77) and spoke protector (CP-WH57/53) are also sold separately. Please ask your bicycle dealer for details.
- When using the CS-M750 11-32T cassette sprocket with the WH-M575-disc, the applicable spoke protector is the CP-FH75
- For maximum performance we highly recommend Shimano lubricants and maintenance products.

Model number	CP-WH57	CP-WH53
Applicable wheels	WH-M959-disc WH-M575-disc	WH-M535

**Brake shoe setting position**

WH-M535/M575-disc (For rim brakes)

Make sure that the brake shoes and brake shoe holders do not touch the spokes.

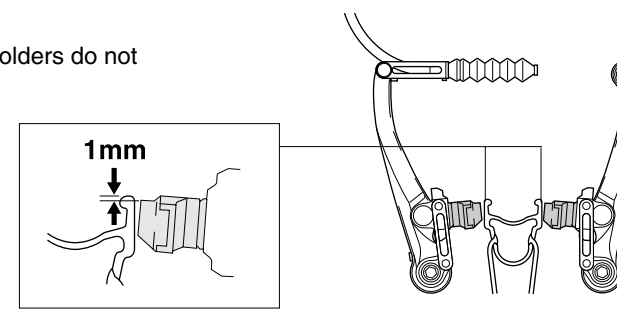

**Replacing the spokes**

Place a washer onto the spoke as shown in the illustration, and then hook the spoke through the rim.

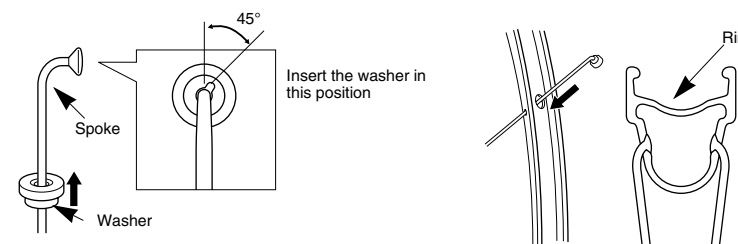

**Spoke lacing**

Lace the spokes as shown in the illustration.

WH-M959-disc/WH-M575-disc

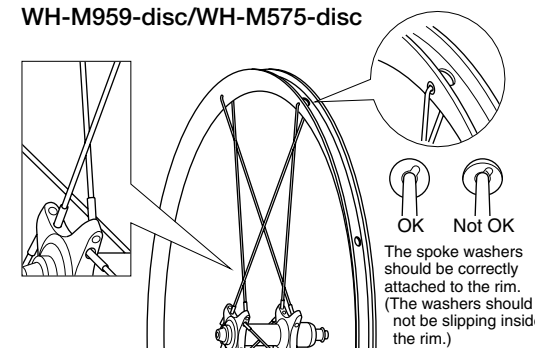

WH-M535(For rear)

At the front, a radial assembly is used at both the left and right

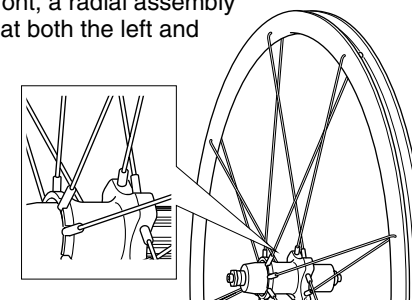

Spoke tension value		
For front	For rear	
980-1180N (86-103 in.lbsf)	Right (sprocket) side 1050-1280N (92-118 in.lbsf)	Left side 980-1180N (86-103 in.lbsf)

※:These values should be used as a guide only.

**Installation of the HG sprockets**

For each sprocket, the surface that has the group mark should face outward and be positioned so that the wide parts of the gear projections on each sprocket and the A part (where the groove width is wide) of the freewheel body are aligned.

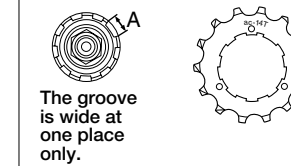

- For installation of the HG sprockets, use the special tool (TL-HG16) to tighten the lock ring.

**Tightening torque:**  
30 - 50 Nm {261 - 434 in. lbs.}

- To replace the HG sprockets, use the special tool (TL-HG16) and TL-SR20 to remove the lock ring.

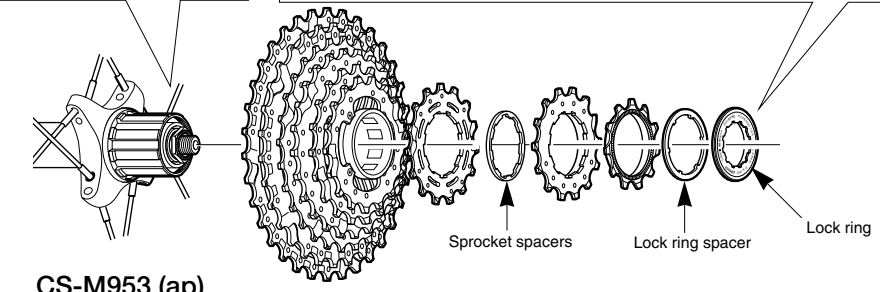
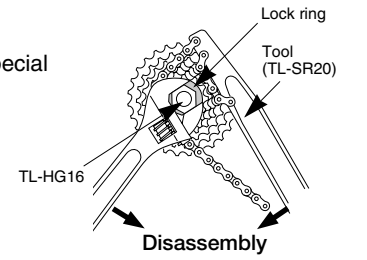

CS-M953 (ap)

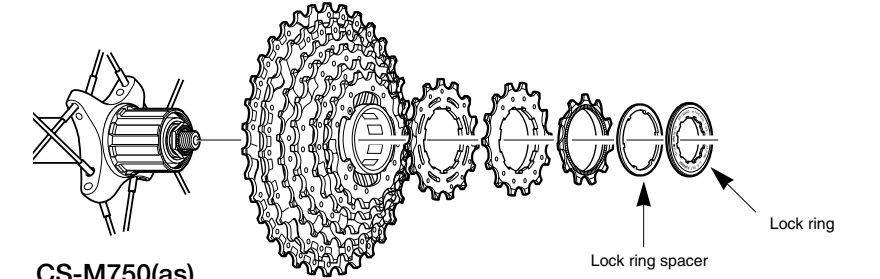

CS-M750(as)

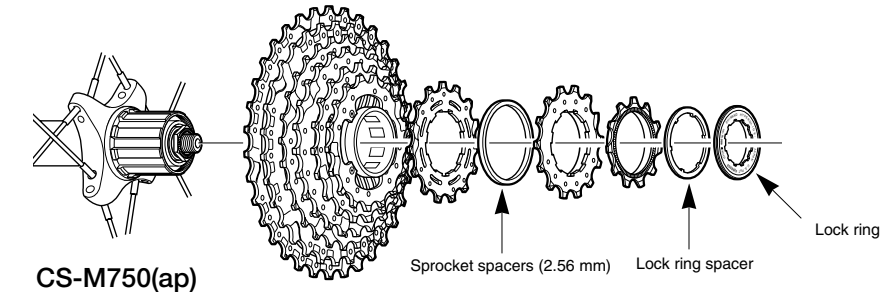

CS-M750(ap)

**Replacement of the freewheel body**

After removing the hub axle, remove the freewheel body fixing bolt (inside the freewheel body), and then replace the freewheel body.

**Note:**  
Do not attempt to disassemble the freewheel body, because it may result in a malfunction.

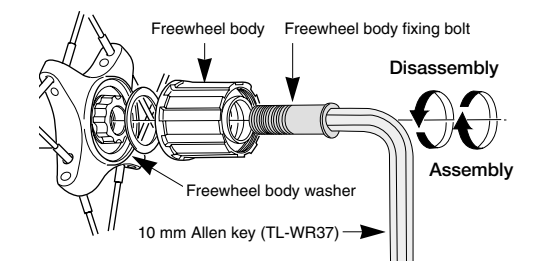

**Tightening torque:**  
35 - 50 Nm {305 - 434 in. lbs.}

**Installation of the rotor (SM-RT75/RT60)**

WH-M959-disc/WH-M575-disc  
(For disc brakes)

Install the rotor and the tightening plate, and then provisionally tighten the rotor fixing bolts as shown in Fig. 1.

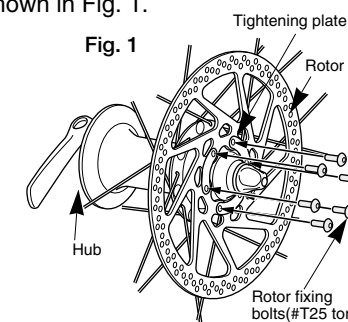

While wearing gloves, apply a force to the rotor to turn it in a clockwise direction as shown in Fig. 2. While doing this, tighten the rotor fixing bolts in the order shown in the illustration.

**Tightening torque:**  
2 - 4 Nm {18 - 35 in. lbs.}

Use a flat-tipped screwdriver or similar tool to bend the edges of the tightening plate over the heads of the bolts as shown in Fig. 3.

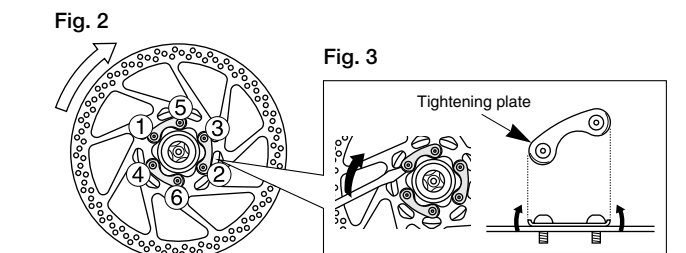

**SERVICE INSTRUCTIONS**

SI-4A60C

WH-M959-disc  
WH-M575-disc  
WH-M535

Wheel

Before use, read these instructions carefully, and follow them for correct use.

In order to realize the best performance, we recommend that the following combination be used.

Wheel	WH-M959-disc	WH-M575-disc	WH-M535
Applicable brakes	Disc brake	Disc brake V-Brake	V-Brake
Chain	CN-7700/CN-HG92/CN-HG72		
Cassette sprocket	CS-M953 CS-M750*	CS-M953/CS-M750/CS-HG70-9	
Applicable tire size	26 × 1.5 ~ 2.25		

\* The WH-M959-disc cannot be used with the CS-M750 11-32, as the alloy sprocket carrier will interfere with the hub shell.

\* Cassette sprockets other than the CS-M750 12-34, 11-34 and the CS-M953 cassette sprockets cannot be used with the WH-M959-disc, as the alloy sprocket carrier will interfere with the hub shell.

**SHIMANO**

SHIMANO AMERICAN CORPORATION  
One Holland Irvine CA 92618 U.S.A. Phone 949-951-5003

SHIMANO EUROPA Industrieweg 24 NL-8071 CT Nurspeet Holland Phone 31-341-272222  
SHIMANO INC. 77 Oimatsu-cho 3-cho Sakai Osaka 590-8577 Japan Phone 0722-23-3243  
Please note: specifications are subject to change for improvement without notice. (English)  
© Nov. 2000 by Shimano Inc. XBC SZK Printed in Japan

These service instructions are printed on recycled paper and can be recycled again

